

WET WELL/VALVE BOX LAYOUT

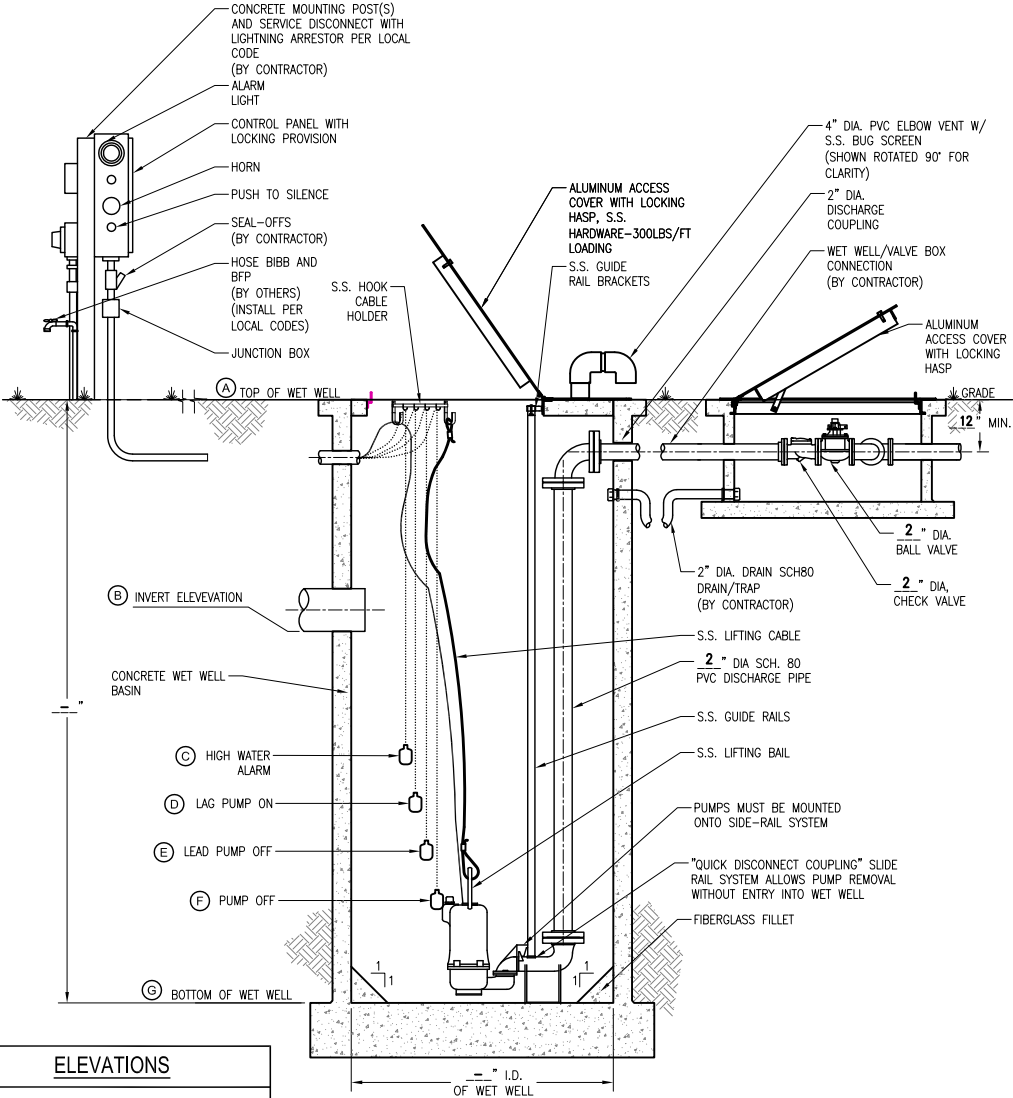
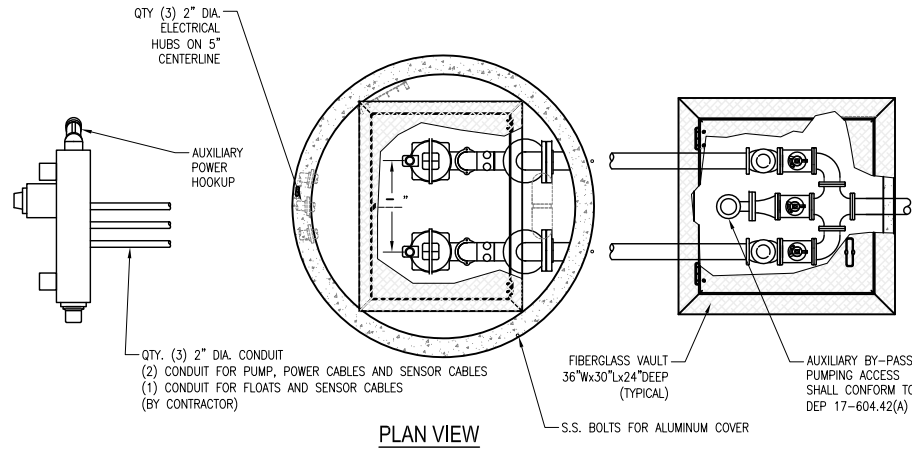

ELEVATIONS	
(A)	TOP OF WET WELL
(B)	INLET INVERT
(C)	HIGH WATER ALARM
(D)	LAG PUMP ON
(E)	LEAD PUMP ON
(F)	PUMP OFF
(G)	BOTTOM OF WET WELL

SECTION VIEW

FDEP REQUIREMENTS
PROVIDE 3/4" WATER LINE WITH A 3/4" RPZ.
ALL ELECTRICAL PANELS SHALL BE ABOVE THE 100 YEAR FLOOD ELEVATION.

PUMP DATA TABLE	
PUMP MODEL	--
IMPELLER DIAMETER	--
PUMP DESIGN CAPACITY	-- GPM
PUMP DESIGN TDH	-- FT
SECONDARY CAPACITY	-- GPM
SECONDARY TDH	-- FT
HORSEPOWER	-- HP
VOLTAGE	-- V
PHASE	-- PH
DISCHARGE SIZE	-- "
NOTES:	--

GENERAL NOTES

PUMPS SHALL BE OF THE SUBMERSIBLE TYPE (MANUFACTURED BY HYDOMATIC OR HOMA). EACH PUMP SHALL BE MOUNTED ON A Ø2" RAIL SYSTEM. THE RAIL SYSTEM SHALL BE SELF ENGAGING RESULTING IN A LEAKPROOF COUPLING. THE RAIL SYSTEM SHALL INCLUDE THE BASE ELBOW, DISCHARGE FLANGE ASSEMBLY, 304SS GUIDE RAILS, 316SS UPPER GUIDE BRACKET, 316SS LIFTING BAIL AND CABLE, AND A SIX-HOOK 316SS CABLE HOLDER. THE RAIL SYSTEM SHALL BE MOUNTED AND PRE-PIPED BY THE PUMP SUPPLIER.

PUMP CONSTRUCTION
THE PUMP VOLUTE, MOTOR AND SEAL HOUSING SHALL BE CONSTRUCTED OF CAST IRON. ALL EXTERNAL FASTENERS SHALL BE SERIES 300 STAINLESS STEEL. THE PUMP SHAFT SHALL BE CONSTRUCTED OF SERIES 416 STAINLESS STEEL.

IMPELLER
THE IMPELLER SHALL BE OF MULTI-VANE, SEMI-OPEN CONSTRUCTION. THE IMPELLER SHALL BE STATICALLY AND HYDRAULICALLY BALANCED.

CUTTERS
A CUTTER ASSEMBLY SHALL BE MOUNTED ON THE SUCTION SIDE OF THE PUMP WITH DIRECT DISCHARGE INTO THE PUMP IMPELLER. THE GRINDER SHALL BE CAPABLE OF GRINDING ALL MATERIALS FOUND IN NORMAL, DOMESTIC SEWAGE. BOTH THE STATIONARY AND ROTATING CUTTERS SHALL BE CONSTRUCTED OF HARDENED STEEL.

MOTOR
THE MOTOR SHALL BE MOUNTED IN A SEALED, SUBMERSIBLE TYPE HOUSING. THE STATOR SHALL BE SECURELY HELD IN PLACE WITH A REMOVABLE END RING AND THREADED FASTENERS FOR EASE OF REMOVAL WITHOUT THE USE OF HEAT OR A PRESS. THE MOTOR WILL HAVE TWO HEAVY-DUTY BALL BEARINGS; ONE UPPER (RADIAL) AND ONE LOWER (THRUST), TO SUPPORT THE SHAFT. THE MOTOR SHALL BE EQUIPPED WITH A WINDING THERMOSTAT THAT IS WIRED TO SHUT THE MOTOR OFF IN CASE OF MOTOR OVERHEATING.

SEAL CHAMBER
THE PUMP SHALL HAVE TWO MECHANICAL SEALS, MOUNTED IN TANDEM WITH AN OIL CHAMBER BETWEEN THE SEALS. THE PUMP SHALL BE EQUIPPED WITH A SEAL LEAK DETECTION PROBE AND WARNING SYSTEM BY USING A SEAL FAILURE SENSOR INSTALLED IN THE SEAL CHAMBER.

WET WELL
WET WELL SHALL BE PRE-CAST CONCRETE AND SECTIONS SHALL BE REINFORCED IN CONFORMING WITH ASTM C478 AND C913 (LATEST REVISIONS). CONTRACTOR SHALL SUPPLY WET WELL AND SHALL CONFIRM UNITS ARE STRUCTURALLY SOUND FOR DEPTH REQUIRED.

VALVE BOX
THE VALVE BOX SHALL BE CONCRETE WITH AN ALUMINUM LOCKABLE COVER. STANDARD SIZE VALVE BOX IS 3' X 2 1/2' X 2'.

VALVES
VALVES SHALL BE SEWAGE SWING CHECK WITH CLEAN-OUT PORTS AND BRASS GATE VALVES.

HATCH COVER
THE HATCH COVERS SHALL ALLOW FOR MAXIMUM ACCESS TO THE WET WELL AND VALVE BOX. THE HATCH COVER SHALL BE ALUMINUM WITH STAINLESS STEEL FASTENERS, RATED FOR 300 PSF OR GREATER. THE HATCH COVER SHALL INCLUDE A SINGLE OR DUAL DOOR OF DIMENSIONS SPECIFIED BY THE PUMP MANUFACTURER FOR PROPER PUMP CLEARANCE. THE COVER SHALL BE MANUFACTURED BY US FABRICATION, OR EQUAL.

FLOATS
FLOATS SHALL BE ANCHOR SCIENTIFIC ROTO-FLOATS OR EQUAL.

CONTROLS
THE CONTROL PANEL SHALL BE UL508 LISTED. A NEMA 3R ENCLOSURE SHALL BE PROVIDED IN EITHER FIBERGLASS OR STAINLESS STEEL. THE PANEL SHALL INCLUDE AN ALTERNATING CONTROL SCHEME (DUPLEX AND ABOVE), MAIN CIRCUIT BREAKER, GENERATOR RECEPTACLE, HIGH LEVEL ALARM LIGHT AND HORN, ELAPSED TIME METERS, VOLTAGE OR PHASE MONITOR, SEAL FAILURE AND OVERLOAD SENSORS. THE LIGHTNING ARRESTOR SHALL BE PROVIDED BY CONTRACTOR.

ELECTRICAL
ALL ELECTRICAL WORK SHALL BE IN ACCORDANCE WITH LOCAL CODES.

SUPPLIER
PUMP SUPPLIER SHALL PROVIDE SUBMERSIBLE PUMPS, SLIDE RAIL ASSEMBLIES, CONTROL PANEL, FLOAT SWITCHES, ALUMINUM HATCHES AND ACCESSORIES TO INSURE PROPER OPERATIONS AND WARRANTY.

PUMP PACKAGE SHALL BE SUPPLIED BY BARNEY'S PUMPS INC. IN LAKELAND (863-665-8500), CORAL SPRINGS (954-346-0669), OR JACKSONVILLE (904-260-0669), FL.

PUMP PERFORMANCE CURVE

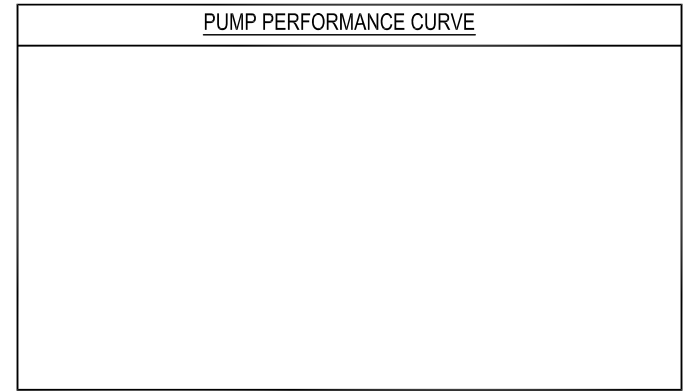

ELECTRICAL DATA

INCOMING POWER: 230V 1Ø
(CONTRACTOR TO VERIFY)

ENCLOSURE AND DEADFRONT LAYOUT (TYPICAL)

(OUTER DOOR NOT SHOWN FOR CLARITY)

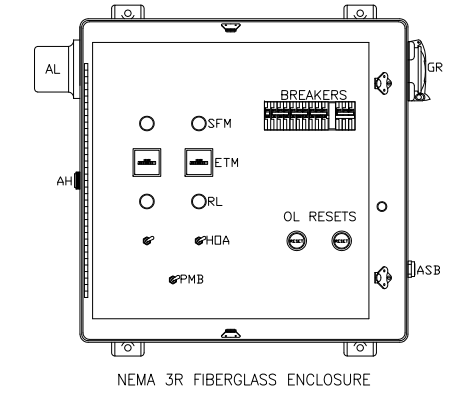

TERMINAL STRIP

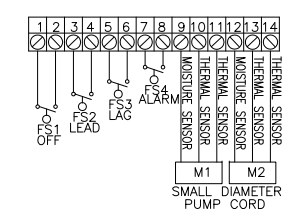

SINGLE PHASE WIRING DIAGRAM

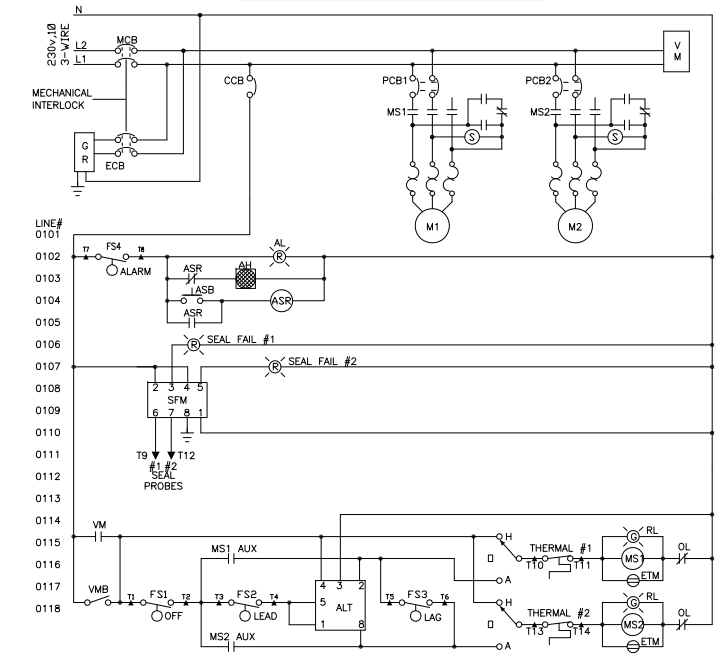

ALL PANELS SHALL BE UL LISTED AND CONFORM TO FLORIDA DEP 64-604.42A

- 1) GENERATOR RECEPTACLE WITH INTERLOCK FOR EMERGENCY POWER CONNECTION.
- 2) SURGE AND LIGHTNING PROTECTION SHALL BE PROVIDED BY CONTRACTOR AND MOUNTED EXTERNAL TO THE CONTROL PANEL.
- 3) PHASE OR VOLTAGE MONITOR SHALL BE PROVIDED IN CONTROL PANEL.
- 4) ALL PANELS, WET WELL, VALVE BOX, AND ACCESS DOORS SHALL HAVE LOCKABLE MECHANISMS. CONTRACTOR TO PROVIDE KEYS.
- 5) POST UNOBSTRUCTED SIGN MADE OF DURABLE WEATHER RESISTANT MATERIAL WITH THE FOLLOWING: PUBLIC NOTICE: IN CASE OF EMERGENCY CONTACT:
6) THE CONTROL PANEL SHALL BE SUITABLY INSTALLED TO PREVENT SETTLING OR TIPPING.
7) ELECTRICAL CONTRACTOR TO PROVIDE SERVICE DISCONNECT WITH LIGHTNING ARRESTOR MOUNTED PER LOCAL CODES.
8) FLOAT SWITCHES SHALL BE UL LISTED.
9) SHAFT SEAL FAIL DETECTION

LEGEND

ENC	ENCLOSURE	ASB	ALARM SILENCE BUTTON
MCB	MAIN CIRCUIT BREAKER	HOA	HAND OFF AUTO SWITCH
ECB	EMERGENCY CIRCUIT BREAKER	VMB	VOLT MONITOR BYPASS
PCB1,2	PUMP CIRCUIT BREAKER	RL	RUN LIGHT
CCB	CONTROL CIRCUIT BREAKER	IL	INDICATING LIGHT
MS1,2	MOTOR STARTER	SFM	SEAL FAIL MODULE
OL	OVERLOAD HEATER	ASR	ALARM SILENCE RELAY
GR	GENERATOR RECEPTACLE		RUN CAPACITOR
VM	VOLT MONITOR		START RELAY
ETM	ELAPSED TIME METER	PM	PHASE MONITOR
ALT	ALTERNATOR	PMB	PHASE MONITOR BYPASS
AH	ALARM HORN		
AL	ALARM LIGHT		

UL LISTED
ENCLOSED INDUSTRIAL CONTROL PANEL

PANEL MANUFACTURER SHALL BE UL 508 AND UL 698A LISTED.

BARNEY'S PUMPS, INC.
PO BOX 3529, LAKELAND, FL 33802
PHONE: (863) 665-8500 FAX: (863) 666-3858

PROJECT: GRINDER DUPLEX CONCRETE LIFT STATION - SINGLE PHASE

CUSTOMER: SALESPERSON:

TITLE: DATE: 04/04/2014 DWG. #: WW2GCVFM_1PH DRAWN BY: R.R.B. REV. 0