

QTY. (2) _____ INCH DIA.
ELECTRICAL HUBS ON
5 INCH CENTERLINE

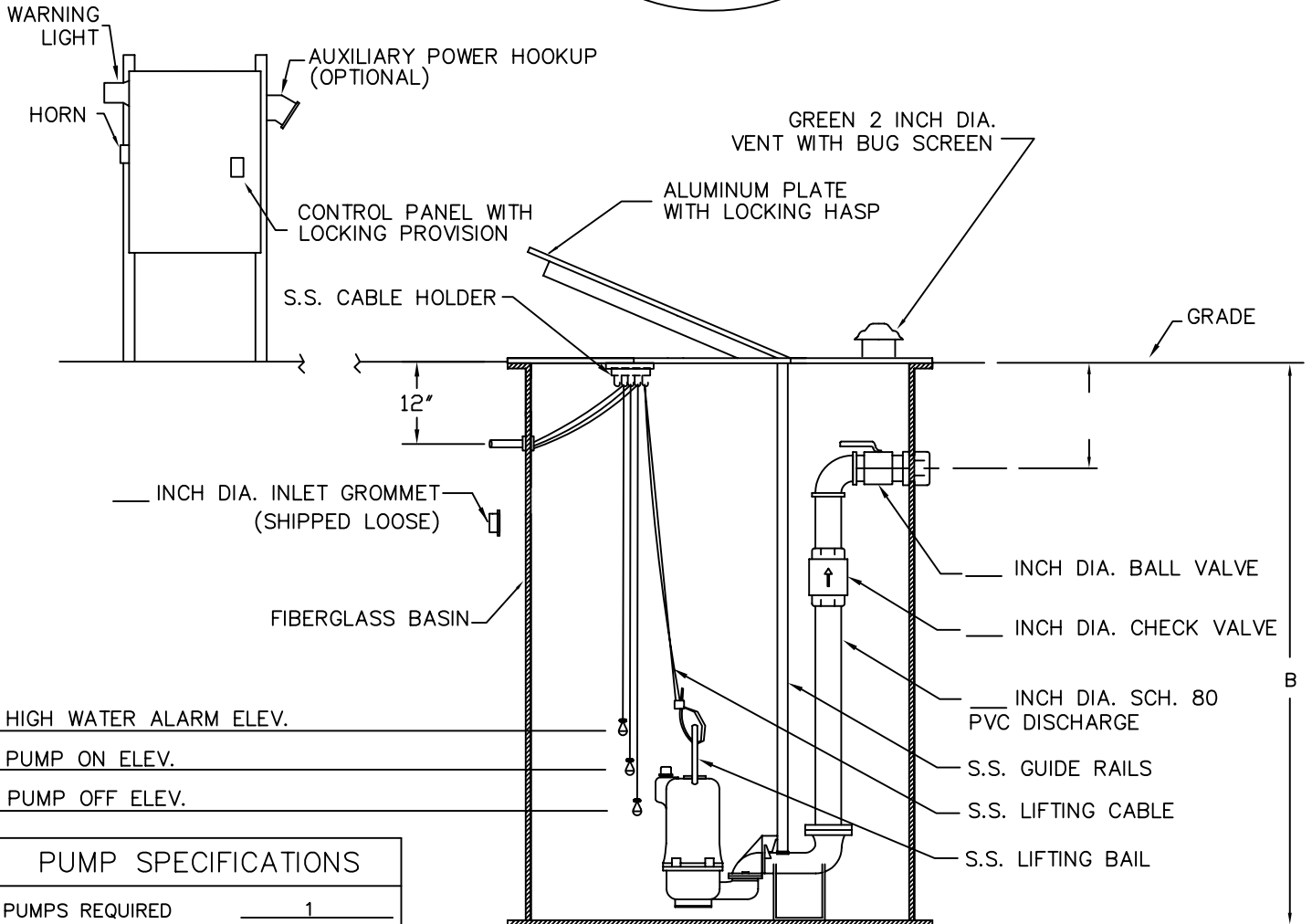
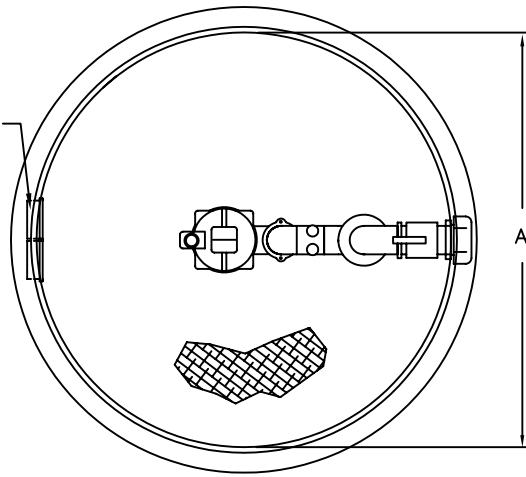

PUMP SPECIFICATIONS	
PUMPS REQUIRED	1
MANUFACTURER	HYDROMATIC
MODEL NUMBER	_____
PUMP SIZE	_____
CAPACITY EACH (GPM)	_____
TOTAL HEAD (FEET)	_____
IMPELLER DIAMETER	_____
MOTOR HP REQUIRED	_____
SPEED (RPM)	_____
ELECTRICAL	_____
TANK	
A (DIA.)	B (HEIGHT)
24"	60"
24"	72"

BARNEY'S PUMPS, INC.			
DESCRIPTION: SIMPLEX LIFT STATION			
PROJECT: _____			
CUSTOMER: _____			
DATE: _____	TICKET #: _____	DRAWN BY: SET	DRAWING #: WW1GFIF0
NOT TO SCALE			